

1177 Series Shelf Back Lavatory Faucet

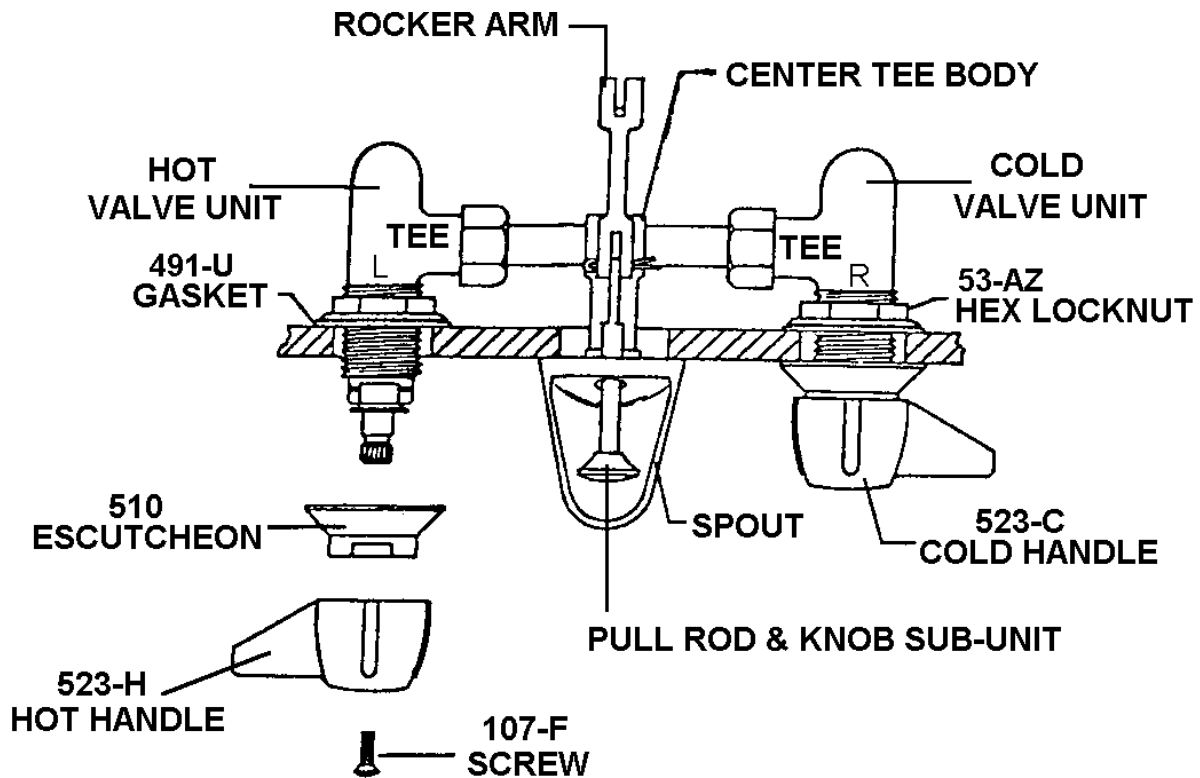

FAUCET INSTALLATION:

1. Tee body will assemble to 4" to 6" centers. (For 4" centers, cut off 1/4" from each end of tee body.)
2. Assemble right and left valve bodies to tee body as shown.
3. Turn locknuts (53-AZ) down the full length of each valve body and place one (1) gasket (491-U) on each valve body.
4. Place center tee body (U-2171-A) and right (U-2170-AR) and left (U-2170-AL) valve bodies in lavatory as shown. (Rubber o-ring should be greased for easy assembly.)
5. Assemble spout to center tee body as shown. (Spout should be hand tightened for a proper seal against the o-ring.)
6. Assemble escutcheons (510) and handles (523-C & 523-H) as shown.
7. Tighten locknuts (53-AZ) against back of lavatory.
8. Connect faucet to water supply lines as indicated by hot and cold handles. Brass coupling nuts are provided.
9. Insert pull rod and knob sub-unit (SU-754-KA) thru spout and assemble to rocker arm as shown with the guide for installing the pop-up drain.
10. Remove aerator and flush faucet for approximately ten minutes before replacing aerator on spout.

1177 Series Shelf Back Lavatory Faucet

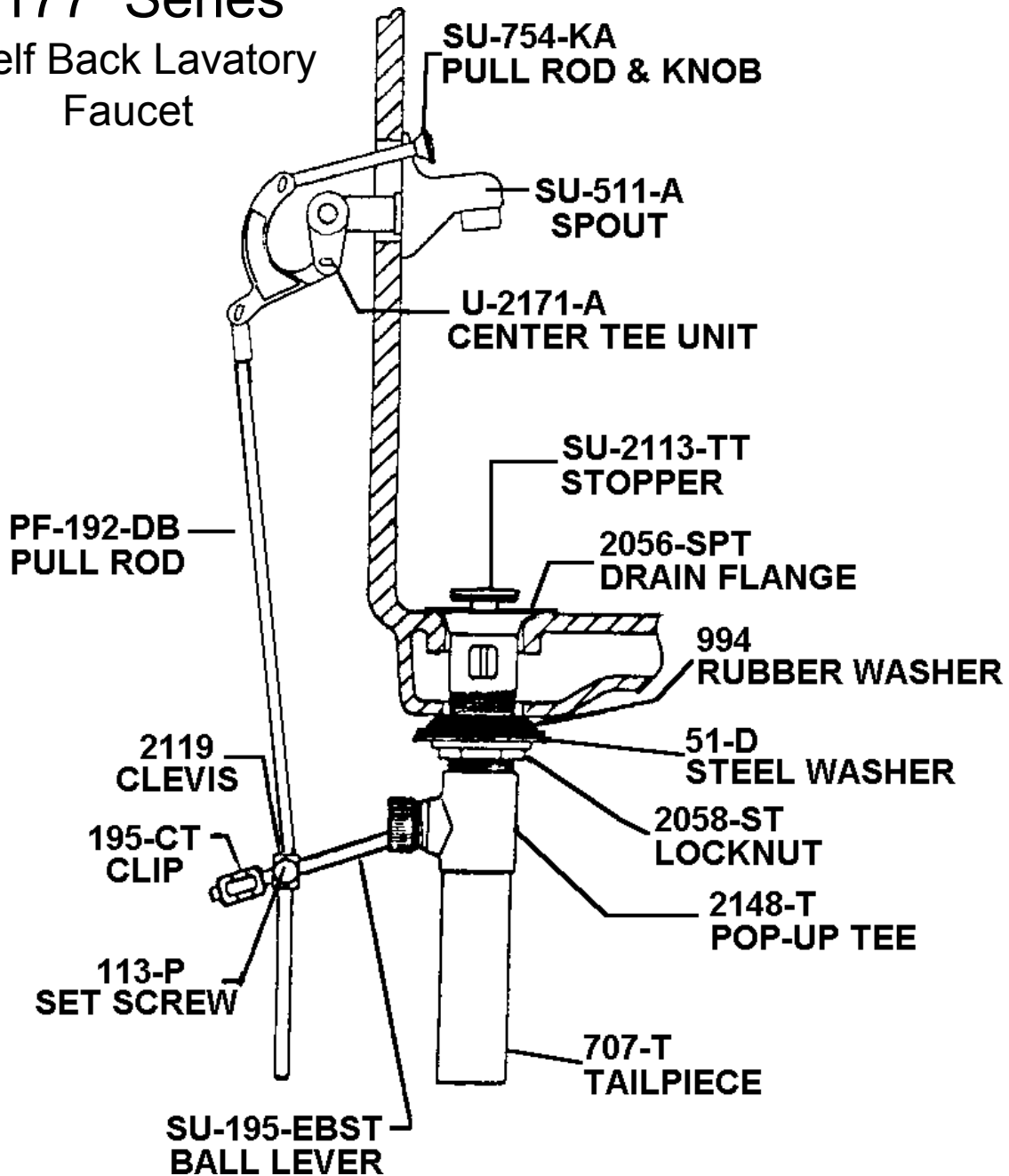

GUIDE FOR INSTALLING POP-UP DRAIN:

1. Remove stopper and drain flange from pop-up tee and remove locknut, steel washer and rubber washer from drain flange.
2. Apply a layer of soft (plumber set) to the underside of drain flange and insert downward thru lavatory.
3. Assemble rubber washer, steel washer and locknut to drain flange as shown. Assemble pop-up tee to drain flange, tighten locknut from underside and assemble ball lever to tee as shown. (NOTE: Ball lever points towards the rear.)
4. Assemble pull rod, clevis and clip as shown, tighten set screw and insert stopper.